

NOBILI



Geo

Turboatomizzatori portati e trainati

Tractor mounted and trailed sprayers

Pulverizadores suspendidos y arrastrados





Turboatomizzatore portato per colture arboree, vigneti e frutteti Tractor mounted sprayer for arboriculture, vineyards and orchards Pulverizador suspendido para arboricultura, viñedos y frutales

Gamma di atomizzatori portati con attacco a tre punti, per trattamenti su vigneti, frutteti, uliveti e piante a medio fusto. Particolare cura è stata dedicata alla robustezza della telaistica ed alle prestazioni grazie alle ventole da 750 e 900 mm di diametro. La gamma Geo portata è disponibile dai 300 ai 600 litri di capacità di cisterna. Monta pompe ad alta pressione da 81 e 108 litri/minuto di portata. Altre caratteristiche di serie: cisterna principale + cisterna lava mani + cisterna lava impianto tutte in polietilene, coperchi a boccaporto ribaltabili con innesto a baionetta, filtro a boccaporto, filtro aspirazione esterno con valvola anti svuotamento, by-pass per lavaggio anche con cisterna piena, agitazione interna, trasmissione ad ingranaggi con folle -1 velocità su elica Ø750 -2 velocità su elica Ø900, convogliatore gruppo ventola zincato a caldo.

Range of tractor mounted sprayers with three-point linkage; for treatment of vineyards, orchards, olive groves and medium-trunk trees. Particular care has been put to the robustness of the frame and to the performances thanks to the 750 and 900 mm diameter fans. Available with tanks from 300 to 600 l. capacity; equipped with high pressure pumps with 81 and 106 l/min. pump delivery. Other standard features: main tank + hand-washing tank + circuit washing tank all made of polyethylene; hinged tank covers with bayonet-type mount; tank strainer; external suction filter with anti-emptying valve; by-pass cleaning even with full tank; internal agitation; transmission by gears with neutral, with 1-speed by 750 mm dia. fan and 2-speed by 900 mm dia. fan; hot galvanized fan housing.

Gama de atomizadores con enganche a los tres puntos del tractor, para tratamientos en viñedos, frutales, olivares y árboles a medio tronco. Se ha prestado especial atención a la estructura de los chasis muy robustos y al rendimiento gracias a los ventiladores de 750 y 900 mm de diámetro. La gama Geo suspendida está disponible con tanques de polietileno desde 300 hasta 600 litros de capacidad. Se configura con bombas de alta presión de 81 y 106 litros/minutos de caudal. Otras características estándar: depósito principal + tanque lava manos + tanque limpia circuito de polietileno, tapas para la boca del tanque articuladas tipo bayoneta, filtro en la boca del tanque, filtro de aspiración externo con válvula anti-vaciado, by-pass para limpiar aún con el depósito lleno, agitación interna, transmisión por engranajes con punto muerto - de 1 velocidad su hélice Ø750 - de 2 velocidades su hélice Ø900, caja del ventilador galvanizada en caliente.

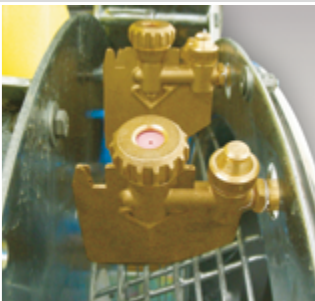

Getti singoli montati su palette in ottone brevettata, con anti goccia. Ugelli in ceramica.

Single nozzles on patented brass vane with drop-stop; ceramic tip-nozzles.

Boquillas simples sobre paleta de latón brevettata, con anti-goteo. Boquillas de cerámica.



Comando a distanza manuale a 2 vie, con leva apertura/chiusura generale.

Manual 2-way remote control unit with lever for general opening/closing.

Mando manual remoto de 2 vías, con apertura/cierre general.

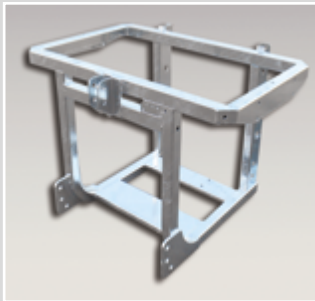

Telaio monoblocco zincato a caldo, predisposto per applicazione di barre diserbanti meccaniche.

Hot galvanized single-bloc frame, ready for the application of mechanical herbicide booms.

Chasis monobloque galvanizado en caliente, diseñado para aplicación de barras herbicidas mecánicas.

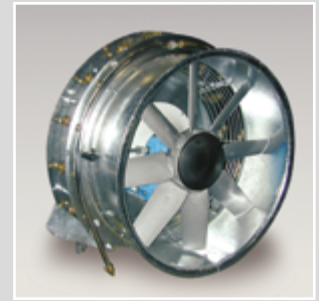

Ventola con pale in nylon ad inclinazione variabile.

Fan with variable pitch blades made of nylon.

Ventilador con palas en nylon de paso variable.



Turboatomizzatore trainato per colture erbacee, vigneti e frutteti Trailed sprayer for arboriculture, vineyards and orchards Pulverizador arrastrado para arboricultura, viñedos y frutales

Gamma di atomizzatori trainati professionali a grande volume d'aria per trattamenti su vigneti, frutteti, uliveti e piante ad alto fusto. Disponibili con cisterne dai 600 ai 2000 litri di capacità, sono allestiti con ventole da 750, 900 (standard e super) e 1050 mm di diametro. Montano pompe di produzione Nobili ad alta pressione da 110 a 140 litri al minuto di portata. Sono progettati per ricevere un gran numero di accessori ed optional per qualsiasi esigenza. Altre caratteristiche di serie: doppio boccaporto ribaltabile con innesti a baionetta, by-pass per lavaggio circuito con cisterna piena, filtro a boccaporto, telaio zincato a caldo predisposto per applicazione barra meccanica, filtro aspirazione esterno con valvola anti svuotamento, agitazione interna, timone ad occhio per traino, pedana di salita (1500 - 2000 litri), convogliatore gruppo ventola zincato a caldo.

Range of professional trailed sprayers with a large air volume, for the treatment of vineyards, orchards, olive groves and tall-trunk trees. Available with tanks from 600 to 2000 l. capacity; supplied with 750, 900 (both standard and super) as well as 1050 mm diameter fans. Equipped with high pressure pumps produced by Nobili from 110 to 140 l/min. pump delivery. Designed to fit a large number of accessories and optional equipment for any need. Other standard features: twin hinged tank covers with bayonet-type mount; by-pass cleaning even with full tank; tank strainer; hot galvanized frame ready for the application of mechanical booms; external suction filter with anti-emptying valve; internal agitation; towing-eye drawbar; access step (1500 - 2000 l.); hot galvanized fan housing.



Gama de atomizadores arrastrados profesionales de gran volumen de aire para tratamientos en viñedos, frutales, olivares y árboles a alto tronco. Disponible con tanque desde 600 hasta 2000 litros de capacidad, se configuran con ventiladores de 750, 900 (estándar y super) y 1050 mm de diámetro. Bombas de producción Nobili de alta presión de 110 a 140 litros por minuto de caudal. Están diseñados para recibir un gran número de accesorios y equipos opcionales para cualquier necesidad. Otras características estándar: dos bocas en el tanque con tapa articulada tipo bayoneta, by-pass para limpiar el circuito con depósito lleno, filtro en la boca del tanque, chasis galvanizado en caliente diseñado para aplicación de barras mecánicas, filtro aspiración externo con válvula anti-vaciado, agitación interna, barra de tiro con ojo para remolque, estribo de acceso (1500-2000 litros), caja del ventilador galvanizada en caliente.



Tre cisterne in polietilene incorporate e separate (principale, lavamani e lava impianto).

3 integrated and independent tanks of polyethylene (main, hand-and circuit-washing tank).

Trés tanques de polietileno agregados y independientes (principal, lavamanos y limpia circuitos).

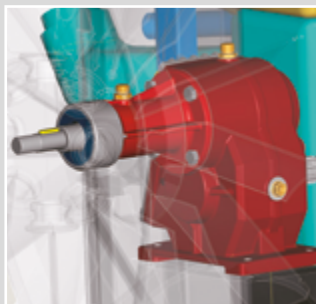

Trasmissione ad ingranaggi 2 velocità con folle.

Transmission by gears with 2-speed and neutral.

Transmisión de engranajes de 2 velocidades y punto muerto.



Pompe originali Nobili ad alta pressione e in alluminio anodizzato serie "S" a membrane.

Nobili original high pressure pumps made of anodized aluminium series "S" on diaphragms.

Bombas originales Nobili de alta presión y de aluminio anodizado serie "S" con membranas.



Getti singoli montati su palette in ottone brevettata, con anti goccia ed ugelli in ceramica.

Single nozzles on patented brass vane with drop-stop; ceramic tip-nozzles.

Boquillas simples sobre paleta de latón brevettata, con anti-goteo. Boquillas de cerámica.



Telaio anteriore ad arco

Arc-shaped front frame

Chasis anterior en forma de arco



Filtro autopulente in mandata e separatore universale per servizi

Self-cleaning high pressure filter and universal divider for services

Filtro auto-limpicante en presión y separador universal para servicios



Ventola con frizione e pale ad inclinazione variabile.

Fan with clutch and variable pitch blades.

Ventilador con embrague y palas de paso variable.



Gruppo comando a distanza manuale a 2 vie, in alluminio, con leva unica per chiusura parziale/generale e scarico.

Manual 2-way remote control unit made of aluminium, with single lever for partial/general closing and discharge.

Mando manual remoto de 2 vías, de aluminio, con palanca única por cierre parcial/general y vaciado.



Correttore aria (di serie su Geo Ø900).

Air straightener (standard by GEO 900 dia.).

Contra hélice corrector del aire (estándar por Geo Ø900).

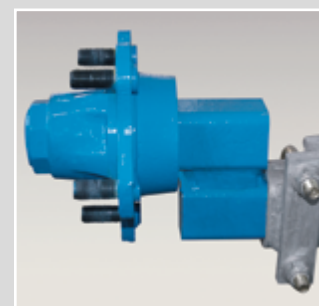

Assali con mozzi regolabili in altezza e larghezza.

Axles with hubs adjustable in height and width.

Ejes con bujes ajustables en altura y anchura.

Accessori e parti a completamento - Optional equipment - Accesorios y partes para completar

Per Portati - For tractor mounted - Para suspendidos



Cestello miscelatore in plastica
Plastic mixing basket
Mezclador de plástico



Ruote fisse
Fixedwheels
Ruedas fijas

Per Trainati - For trailed - Para arrastrados



Cestello miscelatore inox
Stainless steel mixing basket
Mezclador de acero inoxidable



Timone sterzante ai bracci del sollevatore
Steering drawbar for lifting unit arms
Enganche giratorio para brazos del levantador



Timone sterzante TSS al traino della trattrice
Steering drawbar TSS for tractor towing
Enganche giratorio TSS de arrastre del tractor



Gruppo ventola UT a doppia bocca con recupero aria, per apparati fogliari molto alti e/o con molta vegetazione (solo per Ø900 Super)

"UT" blower with double air exit and air recovery, for very high frond vegetation and/or with much vegetable mass (only by 900 dia. Super)

Grupo ventilador UT con doble boca de salida y recuperó de aire, para aparatos foliares muy alto y/o con mucha vegetación (sólo para Ø900 Super)



Omologazione per circolazione stradale a vuoto e pieno carico, con impianto frenante
Homologation for road circulation both with empty and full load, with brake system
Homologación para la circulación carretera en vacío y en plena carga, con sistema frenante



Computer
Computer
Ordenador

Per portati e trainati - For tractor mounted and trailed - Para suspendidos y arrastrados

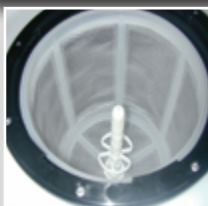

Lava bottiglie
Bottle washing device
Limpia envases



Convogliatore laterale per ventole Ø750 e Ø900
Side conveyor for 750 and 900 dia. fans
Deflector lateral para ventiladores Ø750 y Ø900



Riempitore anti inquinante con tubo Ø40 mm
Antipollution fill-system with hose pipe dia. 40 mm
Cargador anti-contaminante con tubo Ø40



Comando 2 sezioni elettriche con pulsantiera
2-section electric control unit with control box
Mando 2 secciones eléctricas con panel de control



Regolatore pressione elettrico professionale (on/off - pressione - 2 sezioni) con pulsantiera.
Electric pressure regulator for professionals (ON/OFF + pressure + 2 sections) with control box
Regulador de presión eléctrico profesional (on/off - presión - 2 secciones) con panel de mandos



Getto rotante lava cisterna
Rotating nozzle for tank washing
Inyector rotatorio lava tanque





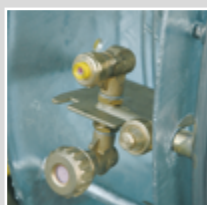





Deflettori
Deflectors
Alerones











Bigetti su palette brevettate in ottone + anti goccia
Bi-nozzles on patented brass vane with drop-stop
Doble-boquillas sobre paleta de latón brevetada + anti-goteo

Caratteristiche tecniche - Technical Specifications - Características Técnicas

Geo									 Potenza					
			lt.	rpm = 540 bar 0-50 litri/1'	Ø	rpm	m/sec	mc/h			HP	kW	A mm	
75-300 P	300	81/50 bar	750	2400	33	24500	3-9	2-7	30-35	22-26	1290	1000	1310	208
75-400 P	400	81/50 bar	750	2400	33	24500	3-9	2-7	30-35	22-26	1440	1210	1200	246
75-500 P	500	81/50 bar	750	2400	33	24500	3-9	2-7	30-35	22-26	1440	1210	1290	250
75-600 P	600	81/50 bar	750	2400	33	24500	3-9	2-7	30-35	22-26	1440	1210	1400	254
90-400 P	400	106/50 bar	900	2100	35	45000	6-12	2-8	50-60	34-45	1460	1210	1200	305
90-500 P	500	108/50 bar	900	2100	35	45000	6-12	2-8	50-60	37-45	1460	1210	1290	310
90-600 P	600	108/50 bar	900	2100	35	45000	6-12	2-8	50-60	37-45	1460	1210	1400	315



Geo									 Potenza					
			lt.	rpm = 540 bar 0-50 litri/1'	Ø	rpm	m/sec	mc/h			HP	kW	A mm	
75-600 T	600	110/ 50 bar	750	2160	33	27300	3-9	2-7	40-50	30-37	2590	970	1180	360
75-800 T	800	110/ 50 bar	750	2160	33	27300	3-9	2-7	40-50	30-37	2880	1050	1310	400
75-1001 T	1000	110/ 50 bar	750	2160	33	27300	3-9	2-7	40-50	30-37	3210	1200	1240	450
75-1001 T	1000	140/50 bar	750	2160	33	27300	3-9	2-7	40-50	30-37	3210	1200	1240	460
90-1001 T	1000	140/50 bar	900	2160	38	51200	4-12	2-8	60-70	45-52	3260	1200	1240	500
90S-1001 T	1000	140/50 bar	900	2160	44	62500	4-16	2-10	60-70	45-52	3300	1200	1240	550
90-1500 T	1500	140/50 bar	900	2160	38	51200	4-12	2-8	60-70	45-52	3600	1550	1455	700
90S-1500 T	1500	140/50 bar	900	2160	44	62500	4-16	2-10	60-70	45-52	3700	1550	1455	710
90-2000 T	2000	140/50 bar	900	2160	38	51200	4-12	2-8	60-70	45-52	3740	1570	1500	750
90S-2000 T	2000	140/50 bar	1050	2160	44	62500	4-16	2-10	60-70	45-52	3840	1570	1500	760
105S-2000 T	2000	140/50 bar	1050	2160	57	77500	4-20	3-14	80-100	60-75	3900	1570	1500	780

Concessionario / Dealer / Distribuidor



40062 MOLINELLA (Bologna) - Italy - Tel. +39.051.88.14.44
www.nobili.com - info@nobili.com